

**SUPERIOR PERFORMANCE**

# **CARBIDE REAMER STRAIGHT & L/H FLUTE**

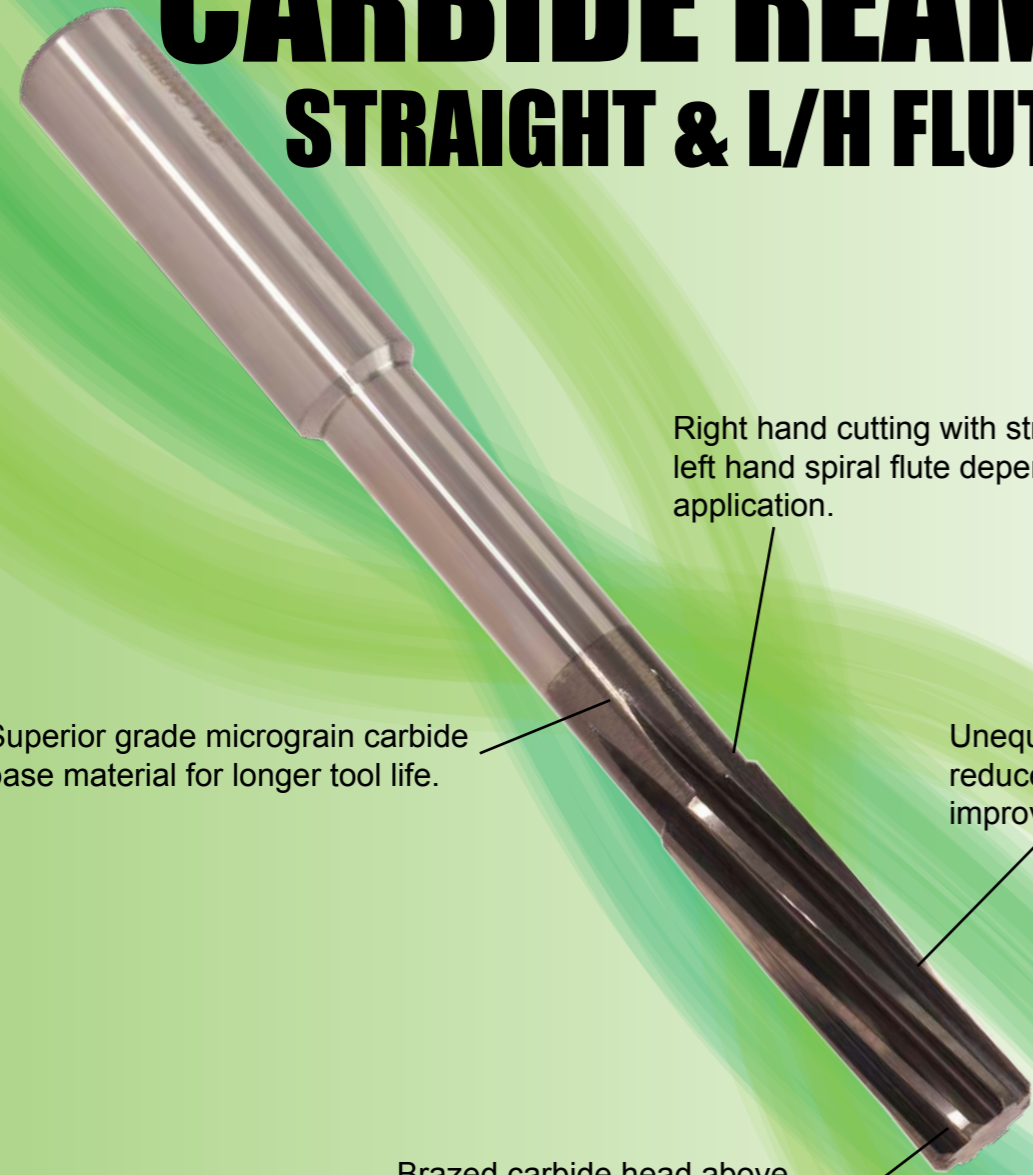

Right hand cutting with straight or left hand spiral flute depending on application.

Superior grade micrograin carbide base material for longer tool life.

Unequal flute spacing for reduced vibration and improved surface finish.

Brazed carbide head above 12.0mm for increased economy.

**IDEAL FOR MATERIAL GROUPS**













# **CARBIDE, HSSCo & HSS REAMERS**



[www.europatool.co.uk](http://www.europatool.co.uk)

●: Excellent ○: Good

P		H		M			K				S					N								O			CARBIDE MACHINE REAMERS								
11	12	13	14	15	16	21	22	23	31	32	33	34	41	42	43	51	52	53	61	62	63	64	71	72	73	74	81	82	83	Code	Item	Description	Page No.		
○	○	○	○	○	○	○	○	○	○	○	○	○	○	○	○	○	○	○	○	○	○	○	○	○	○	○	○	○	○	○	452303		Straight Flute ø2.0mm - 20.0mm	P.156	
○	○	○	○	○	○	○	○	○	○	○	○	○	○	○	○	○	○	○	○	○	○	○	○	○	○	○	○	○	○	○	453303		L/H Spiral Flute ø2.0mm - 20.0mm	P.157	
<b>HSS-E CHUCKING REAMERS S/S</b>																																			
●	●	●	●	○	○	○	○	○	○	○	○	○	○	○	○	○	○	○	○	○	○	○	○	○	○	○	○	○	○	○	452302		Straight Flute ø2.0mm - 20.0mm	P.158	
●	●	●	●	○	○	○	○	○	○	○	○	○	○	○	○	○	○	○	○	○	○	○	○	○	○	○	○	○	○	○	○	453302		L/H Spiral Flute ø2.0mm - 20.0mm	P.160
○	○	○	○	○	○	○	○	○	○	○	○	○	○	○	○	○	○	○	○	○	○	○	○	○	○	○	○	○	○	○	○	454302		L/H Quick Spiral Flute ø4.0mm - 20.0mm	P.162
<b>HSS-E CHUCKING REAMERS MTS</b>																																			
●	●	●	●	○	○	○	○	○	○	○	○	○	○	○	○	○	○	○	○	○	○	○	○	○	○	○	○	○	○	○	○	455302		Straight Flute ø10.0mm - 50.0mm	P.164
●	●	●	●	○	○	○	○	○	○	○	○	○	○	○	○	○	○	○	○	○	○	○	○	○	○	○	○	○	○	○	○	456302		L/H Spiral Flute ø10.0mm - 50.0mm	P.166
<b>HSS MACHINE REAMERS MTS</b>																																			
●	●	●	●	○	○	○	○	○	○	○	○	○	○	○	○	○	○	○	○	○	○	○	○	○	○	○	○	○	○	○	○	457301		L/H Spiral Flute ø3.0mm - 32.0mm	P.168
<b>HSS HAND REAMERS</b>																																			
○	○	○	○	○	○	○	○	○	○	○	○	○	○	○	○	○	○	○	○	○	○	○	○	○	○	○	○	○	○	○	○	450301		Straight Flute ø2.0mm - 60.0mm	P.170
○	○	○	○	○	○	○	○	○	○	○	○	○	○	○	○	○	○	○	○	○	○	○	○	○	○	○	○	○	○	○	○	451301		L/H Spiral Flute ø2.0mm - 60.0mm	P.172
																												Cutting Data	P.174						

► For material group examples, refer to page 2  
 ► For full material group tables, refer to pages 194-199

# CARBIDE MACHINE REAMER STRAIGHT FLUTE



Series No. 452303

▶ cutting conditions : p.174

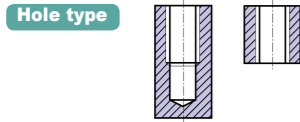

O.D. Tolerances : DIN 1420 for H7  
Shank : DIN6535-HA  
Chamfer angle - Up to 3.0 : 15°  
- Over 3.0 : 45°

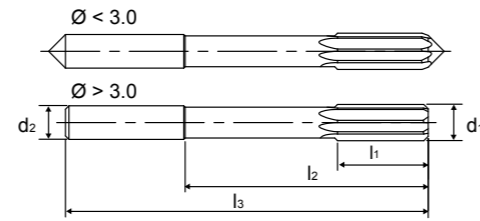

Material - Up to 12.0 : Solid carbide  
- Over 12.0 : Brazed carbide head  
Straight Flute / Right Hand Cut  
Unequal flute spacing

EUROPA CODE	NOMINAL SIZE d1	SHANK DIAMETER d2	CUTTING LENGTH l1	NECK LENGTH l2	OVERALL LENGTH l3	NO.OF FLUTES
4523030200	2.0	4	11	20	50	4
4523030250	2.5	4	14	26	57	4
4523030300	3.0	4	15	31	61	6
4523030350	3.5	4	18	36	70	6
4523030400	4.0	4	19	42	75	6
4523030450	4.5	6	21	46	80	6
4523030500	5.0	6	23	51	86	6
4523030550	5.5	6	26	56	93	6
4523030600	6.0	6	26	56	93	6
4523030650	6.5	8	28	62	101	6
4523030700	7.0	8	31	68	109	6
4523030750	7.5	8	31	68	109	6
4523030800	8.0	8	33	74	117	6
4523030850	8.5	10	33	74	117	6
4523030900	9.0	10	36	80	125	6
4523030950	9.5	10	36	80	125	6
4523031000	10.0	10	38	86	133	6
4523031050	10.5	12	38	86	133	6
4523031100	11.0	12	41	95	142	6
4523031200	12.0	12	44	104	151	6
4523031300	13.0	16	44	104	151	6
4523031400	14.0	16	47	108	160	8
4523031500	15.0	16	50	110	162	8
4523031600	16.0	16	52	118	170	8
4523031700	17.0	20	54	121	175	8
4523031800	18.0	20	56	128	182	8
4523031900	19.0	20	58	129	189	8
4523032000	20.0	20	60	135	195	8

●: Excellent ○: Good

P	H	M	K	S	N	O									
11	12	15	21	22	31	32	41	42	43	61	62	63	64	81	82
○	○	●	●	●	●	●	●	●	●	●	●	●	●	●	●
13	14	16	23	33	34	51	52	53	71	72	73	74	83		
○	○	●	●	●	●	●	●	●	●	●	●	●	●		

# CARBIDE MACHINE REAMER L/H SPIRAL FLUTE



Series No. 453303

▶ cutting conditions : p.174

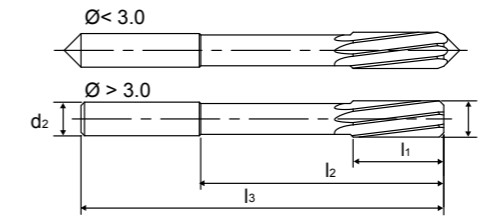

O.D. Tolerances : DIN 1420 for H7  
Shank : DIN6535-HA  
Chamfer angle - Up to 3.0 : 15°  
- Over 3.0 : 45°

Material - Up to 12.0 : Solid carbide  
- Over 12.0 : Brazed carbide head  
L/H Spiral Flute / Right Hand Cut  
Unequal flute spacing

EUROPA CODE	NOMINAL SIZE d1	SHANK DIAMETER d2	CUTTING LENGTH l1	NECK LENGTH l2	OVERALL LENGTH l3	NO.OF FLUTES
4533030200	2.0	4	11	20	50	4
4533030250	2.5	4	14	26	57	4
4533030300	3.0	4	15	31	61	6
4533030350	3.5	4	18	36	70	6
4533030400	4.0	4	19	42	75	6
4533030450	4.5	6	21	46	80	6
4533030500	5.0	6	23	51	86	6
4533030550	5.5	6	26	56	93	6
4533030600	6.0	6	26	56	93	6
4533030650	6.5	8	28	62	101	6
4533030700	7.0	8	31	68	109	6
4533030750	7.5	8	31	68	109	6
4533030800	8.0	8	33	74	117	6
4533030850	8.5	10	33	74	117	6
4533030900	9.0	10	36	80	125	6
4533030950	9.5	10	36	80	125	6
4533031000	10.0	10	38	86	133	6
4533031050	10.5	12	38	86	133	6
4533031100	11.0	12	41	95	142	6
4533031200	12.0	12	44	104	151	6
4533031300	13.0	16	44	104	151	6
4533031400	14.0	16	47	108	160	8
4533031500	15.0	16	50	110	162	8
4533031600	16.0	16	52	118	170	8
4533031700	17.0	20	54	121	175	8
4533031800	18.0	20	56	128	182	8
4533031900	19.0	20	58	129	189	8
4533032000	20.0	20	60	135	195	8

●: Excellent ○: Good

P	H	M	K	S	N	O									
11	12	15	21	22	31	32	41	42	43	61	62	63	64	81	82
○	○	●	●	●	●	●	●	●	●	●	●	●	●	●	●
13	14	16	23	33	34	51	52	53	71	72	73	74	83		
○	○	●	●	●	●	●	●	●	●	●	●	●	●		

# STRAIGHT SHANK CHUCKING REAMER STRAIGHT FLUTE



HSS-E DIN 212 H7  
 15° up to Ø3.75  
 45° over Ø3.75

Series No. 452302

▶ cutting conditions : p.175

Hole type

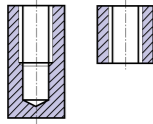

O.D. Tolerances : DIN 1420 for H7  
 Shank Diameter tolerances: h8  
 Straight Flute / Right Hand Cut

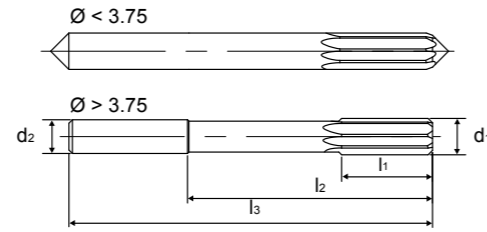

Chamfer angle - Up to 3.75 : 15° (DIN212-A)  
 - Over 3.75 : 45° (DIN212-C)

EUROPA CODE	NOMINAL SIZE d1	SHANK DIAMETER d2	CUTTING LENGTH l1	NECK LENGTH l2	OVERALL LENGTH l3	NO.OF FLUTES
4523020200	2.0	2	11	-	49	4
4523020220	2.2	2.2	12	-	53	4
4523020250	2.5	2.5	14	-	57	4
4523020260	2.6	2.6	14	-	57	4
4523020280	2.8	2.8	15	-	61	4
4523020300	3.0	3	15	-	61	6
4523020310	3.1	3.1	16	-	65	6
4523020320	3.2	3.2	16	-	65	6
4523020350	3.5	3.5	18	-	70	6
4523020360	3.6	3.6	18	-	70	6
4523020370	3.7	3.7	18	-	70	6
4523020400	4.0	4	19	42	75	6
4523020430	4.3	4.5	21	46	80	6
4523020450	4.5	4.5	21	46	80	6
4523020460	4.6	4.5	21	46	80	6
4523020500	5.0	5	23	51	86	6
4523020550	5.5	5.6	26	56	93	6
4523020560	5.6	5.6	26	56	93	6
4523020600	6.0	5.6	26	56	93	6
4523020650	6.5	6.3	28	62	101	6

●: Excellent ○: Good

P	H	M	K	S	N	O									
11	12	15	21	22	31	32	41	42	43	61	62	63	64	81	82
●	●	○	○	○	○	○				○	○	○	○	●	●
13	14	16	23		33	34	51	52	53	71	72	73	74	83	
●	●	○	○		○	○				○	○	○	○		

# STRAIGHT SHANK CHUCKING REAMER STRAIGHT FLUTE



HSS-E DIN 212 H7  
 15° up to Ø3.75  
 45° over Ø3.75

Series No. 452302

▶ cutting conditions : p.175

Hole type

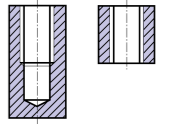

O.D. Tolerances : DIN 1420 for H7  
 Shank Diameter tolerances: h8  
 Straight Flute / Right Hand Cut

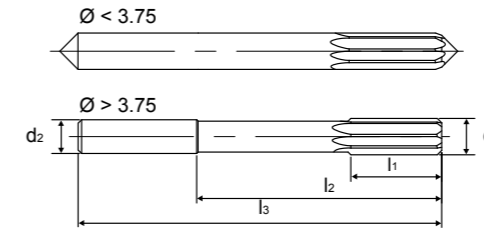

Chamfer angle - Up to 3.75 : 15° (DIN212-A)  
 - Over 3.75 : 45° (DIN212-C)

EUROPA CODE	NOMINAL SIZE d1	SHANK DIAMETER d2	CUTTING LENGTH l1	NECK LENGTH l2	OVERALL LENGTH l3	NO.OF FLUTES
4523020700	7.0	7.1	31	68	109	6
4523230720	7.2	7.1	31	68	109	6
4523020800	8.0	8	33	74	117	6
4523020830	8.3	8	33	74	117	6
4523020850	8.5	8	33	74	117	6
4523020900	9.0	9	36	80	125	6
4523020950	9.5	9	36	80	125	6
4523021000	10.0	10	38	86	133	6
4523021050	10.5	10	38	86	133	6
4523021100	11.0	10	41	95	142	6
4523021200	12.0	10	44	104	151	6
4523021300	13.0	10	44	104	151	6
4523021400	14.0	12.5	47	108	160	8
4523021500	15.0	12.5	50	110	162	8
4523021600	16.0	12.5	52	118	170	8
4523021700	17.0	14	54	121	175	8
4523021800	18.0	14	56	128	182	8
4523021900	19.0	16	58	129	189	8
4523022000	20.0	16	60	135	195	8

●: Excellent ○: Good

P	H	M	K	S	N	O									
11	12	15	21	22	31	32	41	42	43	61	62	63	64	81	82
●	●	○	○	○	○	○				○	○	○	○	●	●
13	14	16	23		33	34	51	52	53	71	72	73	74	83	
●	●	○	○		○	○				○	○	○	○		

# STRAIGHT SHANK CHUCKING REAMER L/H SPIRAL FLUTE

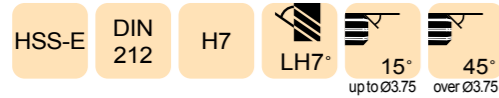

Series No. 453302

▶ cutting conditions : p.175

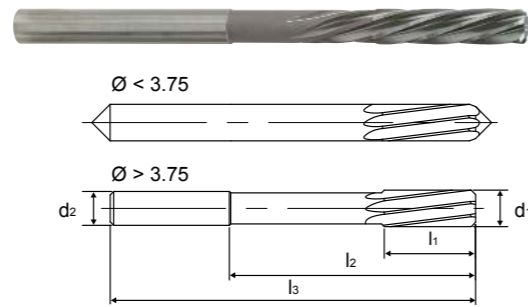

Chamfer angle - Up to 3.75 : 15° (DIN212-B)  
- Over 3.75 : 45° (DIN212-D)

O.D. Tolerances : DIN 1420 for H7  
Shank Diameter tolerances: h8  
L/H Spiral Flute / Right Hand Cut

EUROPA CODE	NOMINAL SIZE d1	SHANK DIAMETER d2	CUTTING LENGTH l1	NECK LENGTH l2	OVERALL LENGTH l3	NO.OF FLUTES
4533020200	2.0	2	11	-	49	4
4533020220	2.2	2.2	12	-	53	4
4533020250	2.5	2.5	14	-	57	4
4533020260	2.6	2.6	14	-	57	4
4533020280	2.8	2.8	15	-	61	4
4533020300	3.0	3	15	-	61	6
4533020310	3.1	3.1	16	-	65	6
4533020320	3.2	3.2	16	-	65	6
4533020350	3.5	3.5	18	-	70	6
4533020360	3.6	3.6	18	-	70	6
4533020370	3.7	3.7	18	-	70	6
4533020400	4.0	4	19	42	75	6
4533020430	4.3	4.5	21	46	80	6
4533020450	4.5	4.5	21	46	80	6
4533020460	4.6	4.5	21	46	80	6
4533020500	5.0	5	23	51	86	6
4533020550	5.5	5.6	26	56	93	6
4533020560	5.6	5.6	26	56	93	6
4533020600	6.0	5.6	26	56	93	6
4533020650	6.5	6.3	28	62	101	6

●: Excellent ○: Good

P	H	M	K	S	N	O									
11	12	15	21	22	31	32	41	42	43	61	62	63	64	81	82
●	●	○	○	○	○	○				○	○	○	○	●	●
13	14	16	23		33	34	51	52	53	71	72	73	74	83	
●	●	○	○		○	○				○	○	○	○		

# STRAIGHT SHANK CHUCKING REAMER L/H SPIRAL FLUTE

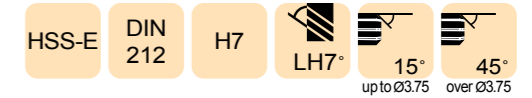

Series No. 453302

▶ cutting conditions : p.175

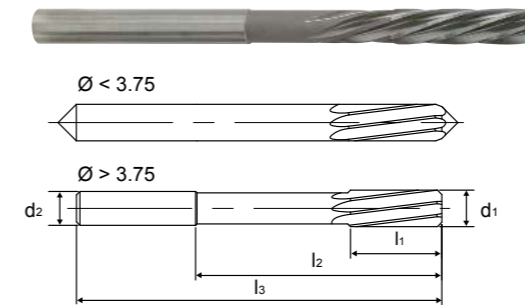

Chamfer angle - Up to 3.75 : 15° (DIN212-B)  
- Over 3.75 : 45° (DIN212-D)

O.D. Tolerances : DIN 1420 for H7  
Shank Diameter tolerances: h8  
L/H Spiral Flute / Right Hand Cut

EUROPA CODE	NOMINAL SIZE d1	SHANK DIAMETER d2	CUTTING LENGTH l1	NECK LENGTH l2	OVERALL LENGTH l3	NO.OF FLUTES
4533020700	7.0	7.1	31	68	109	6
4533020720	7.2	7.1	31	68	109	6
4533020800	8.0	8	33	74	117	6
4533020830	8.3	8	33	74	117	6
4533020850	8.5	8	33	74	117	6
4533020900	9.0	9	36	80	125	6
4533020950	9.5	9	36	80	125	6
4533021000	10.0	10	38	86	133	6
4533021050	10.5	10	38	86	133	6
4533021100	11.0	10	41	95	142	6
4533021200	12.0	10	44	104	151	6
4533021300	13.0	10	44	104	151	6
4533021400	14.0	12.5	47	108	160	8
4533021500	15.0	12.5	50	110	162	8
4533021600	16.0	12.5	52	118	170	8
4533021700	17.0	14	54	121	175	8
4533021800	18.0	14	56	128	182	8
4533021900	19.0	16	58	129	189	8
4533022000	20.0	16	60	135	195	8

●: Excellent ○: Good

P	H	M	K	S	N	O									
11	12	15	21	22	31	32	41	42	43	61	62	63	64	81	82
●	●	○	○	○	○	○				○	○	○	○	●	●
13	14	16	23		33	34	51	52	53	71	72	73	74	83	
●	●	○	○		○	○				○	○	○	○		

# STRAIGHT SHANK CHUCKING REAMER L/H QUICK SPIRAL



HSS-E DIN 212 H7 LH45° FORM E

Series No. 454302

▶ cutting conditions : p.175

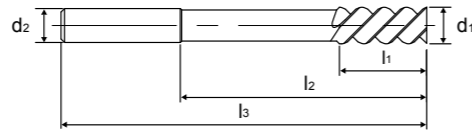

O.D. Tolerances : DIN 1420 for H7  
Shank Diameter tolerances: h8  
L/H Quick Spiral Flute / Right Hand Cut

Chamfer angle : Tapered (DIN212-E)

EUROPA CODE	NOMINAL SIZE d1	SHANK DIAMETER d2	CUTTING LENGTH l1	NECK LENGTH l2	OVERALL LENGTH l3	NO.OF FLUTES
4543020400	4.0	4	19	42	75	3
4543020450	4.5	4.5	21	46	80	3
4543020500	5.0	5	23	51	86	3
4543020550	5.5	5.6	26	56	93	3
4543020600	6.0	5.6	26	56	93	3
4543020650	6.5	6.3	28	62	101	3
4543020700	7.0	7.1	31	68	109	3
4543020800	8.0	8	33	74	117	3
4543020850	8.5	8	33	74	117	3
4543020900	9.0	9	36	80	125	3
4543020950	9.5	9	36	80	125	3
4543021000	10.0	10	38	86	133	3

●: Excellent ○: Good

P		H		M		K		S			N				O	
11	12	15	21	22	31	32	41	42	43	61	62	63	64	81	82	
○	○									●	●	●	●	○	○	
13	14	16	23		33	34	51	52	53	71	72	73	74	83		
○	○									●	●	●	●			

# STRAIGHT SHANK CHUCKING REAMER L/H QUICK SPIRAL



HSS-E DIN 212 H7 LH45° FORM E

Series No. 454302

▶ cutting conditions : p.175

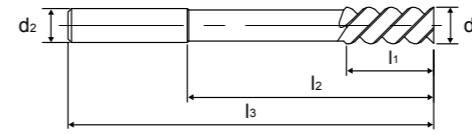

O.D. Tolerances : DIN 1420 for H7  
Shank Diameter tolerances: h8  
L/H Quick Spiral Flute / Right Hand Cut

Chamfer angle : Tapered (DIN212-E)

EUROPA CODE	NOMINAL SIZE d1	SHANK DIAMETER d2	CUTTING LENGTH l1	NECK LENGTH l2	OVERALL LENGTH l3	NO.OF FLUTES
4543021100	11.0	10	41	95	142	3
4543021200	12.0	10	44	104	151	3
4543021300	13.0	10	44	104	151	3
4543021400	14.0	12.5	47	108	160	4
4543021500	15.0	12.5	50	110	162	4
4543021600	16.0	12.5	52	118	170	4
4543021700	17.0	14	54	121	175	4
4543021800	18.0	14	56	128	182	4
4543021900	19.0	16	58	129	189	4
4543022000	20.0	16	60	135	195	4

●: Excellent ○: Good

P		H		M		K		S			N				O	
11	12	15	21	22	31	32	41	42	43	61	62	63	64	81	82	
○	○									●	●	●	●	○	○	
13	14	16	23		33	34	51	52	53	71	72	73	74	83		
○	○									●	●	●	●			

# TAPER SHANK CHUCKING REAMER STRAIGHT FLUTE



HSS-E DIN 208 H7 45°

Series No. 455302

▶ cutting conditions : p.175

Hole type

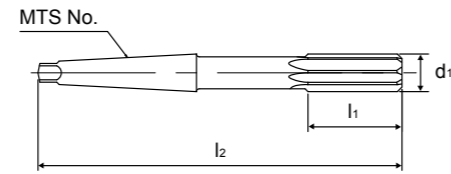
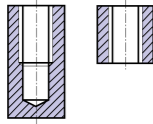

O.D. Tolerances : DIN 1420 for H7  
Straight Flute / Right Hand Cut  
Chamfer angle : 45° (DIN208-A)

EUROPA CODE	NOMINAL SIZE d1	MTS No.	CUTTING LENGTH l1	OVERALL LENGTH l2	NO.OF FLUTES
4553021000	10.0	1	38	168	6
4553021100	11.0	1	41	175	6
4553021200	12.0	1	44	182	6
4553021300	13.0	1	44	182	6
4553021400	14.0	1	47	189	8
4553021500	15.0	2	50	204	8
4553021600	16.0	2	52	210	8
4553021700	17.0	2	54	214	8
4553021800	18.0	2	56	219	8
4553021900	19.0	2	58	223	8
4553022000	20.0	2	60	228	8
4553022100	21.0	2	62	232	8
4553022200	22.0	2	64	237	8
4553022300	23.0	2	66	241	8
4553022400	24.0	3	68	268	8
4553022500	25.0	3	68	268	8
4553022600	26.0	3	70	273	8
4553022700	27.0	3	71	277	10
4553022800	28.0	3	71	277	10

●: Excellent ○: Good

P		H		M		K		S			N				O	
11	12	15	21	22	31	32	41	42	43	61	62	63	64	81	82	
●	●	○	○	○	○	○				○	○	○	○	●	●	
13	14	16	23		33	34	51	52	53	71	72	73	74	83		
●	●	○	○		○	○				○	○	○	○			

# TAPER SHANK CHUCKING REAMER STRAIGHT FLUTE



HSS-E DIN 208 H7 45°

Series No. 455302

▶ cutting conditions : p.175

Hole type

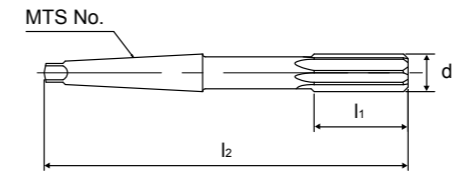
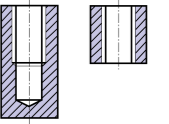

O.D. Tolerances : DIN 1420 for H7  
Straight Flute / Right Hand Cut  
Chamfer angle : 45° (DIN208-A)

EUROPA CODE	NOMINAL SIZE d1	MTS No.	CUTTING LENGTH l1	OVERALL LENGTH l2	NO.OF FLUTES
4553022900	29.0	3	73	281	10
4553023000	30.0	3	73	281	10
4553023100	31.0	3	75	285	10
4553023200	32.0	4	77	317	10
4553023400	34.0	4	78	321	10
4553023500	35.0	4	78	321	10
4553023600	36.0	4	79	325	10
4553023800	38.0	4	81	329	10
4553024000	40.0	4	81	329	10
4553024100	41.0	4	82	333	12
4553024200	42.0	4	82	333	12
4553024300	43.0	4	83	336	12
4553024400	44.0	4	83	336	12
4553024500	45.0	4	83	336	12
4553024600	46.0	4	84	340	12
4553024700	47.0	4	84	340	12
4553024800	48.0	4	86	344	12
4553025000	50.0	4	86	344	12

●: Excellent ○: Good

P		H		M		K		S			N				O	
11	12	15	21	22	31	32	41	42	43	61	62	63	64	81	82	
●	●	○	○	○	○	○				○	○	○	○	●	●	
13	14	16	23		33	34	51	52	53	71	72	73	74	83		
●	●	○	○		○	○				○	○	○	○			

# TAPER SHANK CHUCKING REAMER L/H SPIRAL FLUTE



HSS-E DIN 208 H7 LH7° 45°

Series No. 456302

▶ cutting conditions : p.175

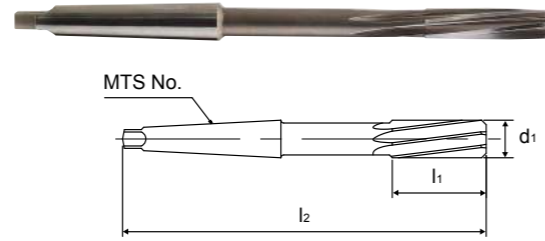

O.D. Tolerances : DIN 1420 for H7  
L/H Spiral Flute / Right Hand Cut  
Chamfer angle : 45° (DIN208-B)

EUROPA CODE	NOMINAL SIZE d1	MTS No.	CUTTING LENGTH l1	OVERALL LENGTH l2	NO.OF FLUTES
4563021000	10.0	1	38	168	6
4563021100	11.0	1	41	175	6
4563021200	12.0	1	44	182	6
4563021300	13.0	1	44	182	6
4563021400	14.0	1	47	189	8
4563021500	15.0	2	50	204	8
4563021600	16.0	2	52	210	8
4563021700	17.0	2	54	214	8
4563021800	18.0	2	56	219	8
4563021900	19.0	2	58	223	8
4563022000	20.0	2	60	228	8
4563022100	21.0	2	62	232	8
4563022200	22.0	2	64	237	8
4563022300	23.0	2	66	241	8
4563022400	24.0	3	68	268	8
4563022500	25.0	3	68	268	8
4563022600	26.0	3	70	273	8
4563022700	27.0	3	71	277	10
4563022800	28.0	3	71	277	10

●: Excellent ○: Good

P		H		M		K		S			N				O	
11	12	15	21	22	31	32	41	42	43	61	62	63	64	81	82	
●	●	○	○	○	○	○				○	○	○	○	●	●	
13	14	16	23		33	34	51	52	53	71	72	73	74	83		
●	●	○	○		○	○				○	○	○	○			

# TAPER SHANK CHUCKING REAMER L/H SPIRAL FLUTE



HSS-E DIN 208 H7 LH7° 45°

Series No. 456302

▶ cutting conditions : p.175

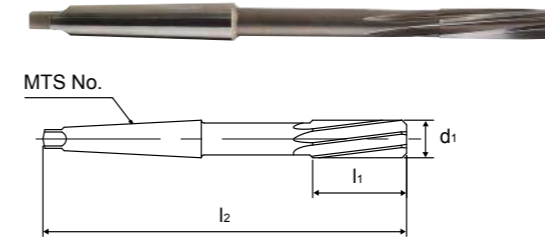

O.D. Tolerances : DIN 1420 for H7  
L/H Spiral Flute / Right Hand Cut  
Chamfer angle : 45° (DIN208-B)

EUROPA CODE	NOMINAL SIZE d1	MTS No.	CUTTING LENGTH l1	OVERALL LENGTH l2	NO.OF FLUTES
4563022900	29.0	3	73	281	10
4563023000	30.0	3	73	281	10
4563023100	31.0	3	75	285	10
4563023200	32.0	4	77	317	10
4563023400	34.0	4	78	321	10
4563023500	35.0	4	78	321	10
4563023600	36.0	4	79	325	10
4563023800	38.0	4	81	329	10
4563024000	40.0	4	81	329	10
4563024100	41.0	4	82	333	12
4563024200	42.0	4	82	333	12
4563024300	43.0	4	83	336	12
4563024400	44.0	4	83	336	12
4563024500	45.0	4	83	336	12
4563024600	46.0	4	84	340	12
4563024700	47.0	4	84	340	12
4563024800	48.0	4	86	344	12
4563025000	50.0	4	86	344	12

●: Excellent ○: Good

P		H		M		K		S			N				O	
11	12	15	21	22	31	32	41	42	43	61	62	63	64	81	82	
●	●	○	○	○	○	○				○	○	○	○	●	●	
13	14	16	23		33	34	51	52	53	71	72	73	74	83		
●	●	○	○		○	○				○	○	○	○			



# TAPER SHANK MACHINE REAMER



HSS DIN 338 H7 LH7\*

Series No. 457301

▶ cutting conditions : p.175

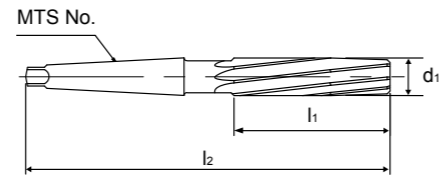

O.D. Tolerances : DIN 1420 for H7  
L/H Spiral Flute / Right Hand Cut  
Chamfer angle : 45° (DIN208-B)

EUROPA CODE	NOMINAL SIZE d1	MTS No.	CUTTING LENGTH l1	OVERALL LENGTH l2
4573010300	3.0	1	31	104
4573010350	3.5	1	35	108
4573010400	4.0	1	38	112
4573010450	4.5	1	41	115
4573010500	5.0	1	44	118
4573010550	5.5	1	48	125
4573010600	6.0	1	48	125
4573010650	6.5	1	50	130
4573010700	7.0	1	54	134
4573010750	7.5	1	54	134
4573010800	8.0	1	58	138
4573010850	8.5	1	58	138
4573010900	9.0	1	62	141
4573010950	9.5	1	62	141
4573011000	10.0	1	67	146
4573011050	10.5	1	67	146
4573011100	11.0	1	71	151
4573011150	11.5	1	71	151
4573011200	12.0	1	76	156

●: Excellent ○: Good

P		H		M		K		S			N				O	
11	12	15	21	22	31	32	41	42	43	61	62	63	64	81	82	
●	●	○	○	○	○	○				○	○	○	○	●	●	
13	14	16	23		33	34	51	52	53	71	72	73	74	83		
●	●	○	○		○	○				○	○	○	○			

# TAPER SHANK MACHINE REAMER



HSS DIN 338 H7 LH7\*

Series No. 457301

▶ cutting conditions : p.175

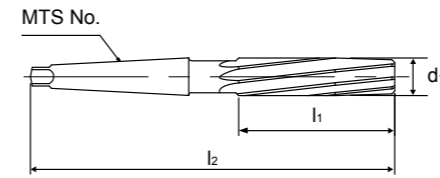

O.D. Tolerances : DIN 1420 for H7  
L/H Spiral Flute / Right Hand Cut  
Chamfer angle : 45° (DIN208-B)

EUROPA CODE	NOMINAL SIZE d1	MTS No.	CUTTING LENGTH l1	OVERALL LENGTH l2
4573011250	12.5	1	76	156
4573011300	13.0	1	76	156
4573011400	14.0	1	81	160
4573011500	15.0	2	81	181
4573011600	16.0	2	87	187
4573011700	17.0	2	87	187
4573011800	18.0	2	94	194
4573011900	19.0	2	94	194
4573012000	20.0	2	100	200
4573012100	21.0	2	100	200
4573012200	22.0	2	106	206
4573012300	23.0	2	106	206
4573012400	24.0	3	114	241
4573012500	25.0	3	114	241
4573012600	26.0	3	114	241
4573012700	27.0	3	124	251
4573012800	28.0	3	124	251
4573012900	30.0	3	124	251
4573013000	32.0	4	133	294

●: Excellent ○: Good

P		H		M		K		S			N				O	
11	12	15	21	22	31	32	41	42	43	61	62	63	64	81	82	
●	●	○	○	○	○	○				○	○	○	○	●	●	
13	14	16	23		33	34	51	52	53	71	72	73	74	83		
●	●	○	○		○	○				○	○	○	○			

# HAND REAMER STRAIGHT FLUTE



HSS DIN 206 H7

Series No. 450301

Hole type

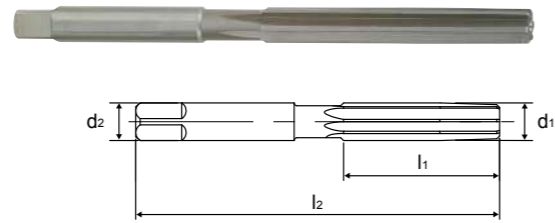
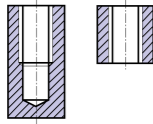

O.D. Tolerances : DIN 1420 for H7  
Shank Diameter = Nominal Reamer Diameter  
Straight Flutes / Right Hand Cut

Chamfer Angle - tapered  
Type of centre - Up to Ø3.75 : external centres  
- Over Ø3.75 : internal centres

EUROPA CODE	NOMINAL SIZE d1 = d2	FLUTE LENGTH l1	OVERALL LENGTH l2	NO.OF FLUTES
4503010200	2.0	25	50	4
4503010220	2.2	27	54	4
4503010250	2.5	29	58	4
4503010280	2.8	31	62	4
4503010300	3.0	31	62	6
4503010320	3.2	33	66	6
4503010350	3.5	35	71	6
4503010400	4.0	38	76	6
4503010450	4.5	41	81	6
4503010500	5.0	44	87	6
4503010550	5.5	47	93	6
4503010600	6.0	47	93	6
4503010700	7.0	54	107	6
4503010800	8.0	58	115	6
4503010900	9.0	62	124	6
4503011000	10.0	66	133	6
4503011100	11.0	71	142	6
4503011200	12.0	76	152	6
4503011300	13.0	76	152	6
4503011400	14.0	81	163	8
4503011500	15.0	81	163	8
4503011600	16.0	87	175	8
4503011700	17.0	87	175	8
4503011800	18.0	93	188	8
4503011900	19.0	93	188	8
4503012000	20.0	100	201	8
4503012200	22.0	107	215	8
4503012400	24.0	115	231	8

●: Excellent ○: Good

P		H		M		K		S			N				O	
11	12	15	21	22	31	32	41	42	43	61	62	63	64	81	82	
○	○	○	○	○	○	○				○	○	○	○	○	○	
13	14	16	23		33	34	51	52	53	71	72	73	74	83		
○	○	○	○		○	○				○	○	○	○			

# HAND REAMER STRAIGHT FLUTE



HSS DIN 206 H7

Series No. 450301

Hole type

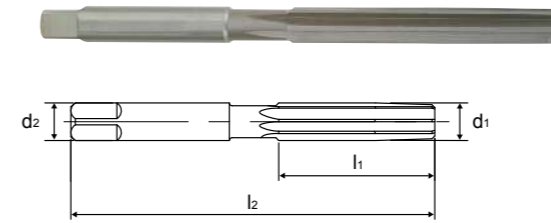
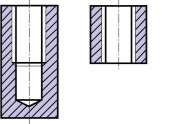

O.D. Tolerances : DIN 1420 for H7  
Shank Diameter = Nominal Reamer Diameter  
Straight Flutes / Right Hand Cut

Chamfer Angle - Tapered  
Type of centre - Up to Ø3.75 : external centres  
- Over Ø3.75 : internal centres

EUROPA CODE	NOMINAL SIZE d1 = d2	FLUTE LENGTH l1	OVERALL LENGTH l2	NO.OF FLUTES
4503012500	25.0	115	231	8
4503012600	26.0	115	231	8
4503012700	27.0	124	247	10
4503012800	28.0	124	247	10
4503012900	29.0	124	247	10
4503013000	30.0	124	247	10
4503013100	31.0	133	265	10
4503013200	32.0	133	265	10
4503013300	33.0	133	265	10
4503013400	34.0	142	284	10
4503013500	35.0	142	284	10
4503013600	36.0	142	284	10
4503013700	37.0	142	284	10
4503013800	38.0	152	305	10
4503013810	38.1	152	305	10
4503013900	39.0	152	305	10
4503014000	40.0	152	305	10
4503014100	41.0	152	305	12
4503014200	42.0	152	305	12
4503014300	43.0	163	326	12
4503014400	44.0	163	326	12
4503014500	45.0	163	326	12
4503014600	46.0	163	326	12
4503014700	47.0	163	326	12
4503014800	48.0	174	347	12
4503014900	49.0	174	347	12
4503015200	52.0	174	347	12
4503016000	60.0	184	367	12

●: Excellent ○: Good

P		H		M		K		S			N				O	
11	12	15	21	22	31	32	41	42	43	61	62	63	64	81	82	
○	○	○	○	○	○	○				○	○	○	○	○	○	
13	14	16	23		33	34	51	52	53	71	72	73	74	83		
○	○	○	○		○	○				○	○	○	○			

# HAND REAMER L/H SPIRAL FLUTE



HSS DIN 206 H7 LH7°

Series No. 451301

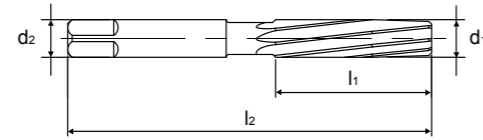

O.D. Tolerances : DIN 1420 for H7  
Shank Diameter = Nominal Reamer Diameter  
L/H Spiral Flutes / Right Hand Cut

Chamfer Angle - Tapered  
Type of centre - Up to Ø3.75 : external centres  
- Over Ø3.75 : internal centres

EUROPA CODE	NOMINAL SIZE d1 = d2	FLUTE LENGTH l1	OVERALL LENGTH l2	NO.OF FLUTES
4513010200	2.0	25	50	4
4513010220	2.2	27	54	4
4513010250	2.5	29	58	4
4513010280	2.8	31	62	4
4513010300	3.0	31	62	6
4513010320	3.2	33	66	6
4513010350	3.5	35	71	6
4513010400	4.0	38	76	6
4513010450	4.5	41	81	6
4513010500	5.0	44	87	6
4513010550	5.5	47	93	6
4513010600	6.0	47	93	6
4513010700	7.0	54	107	6
4513010800	8.0	58	115	6
4513010900	9.0	62	124	6
4513011000	10.0	66	133	6
4513011100	11.0	71	142	6
4513011200	12.0	76	152	6
4513011300	13.0	76	152	6
4513011400	14.0	81	163	8
4513011500	15.0	81	163	8
4513011600	16.0	87	175	8
4513011700	17.0	87	175	8
4513011800	18.0	93	188	8
4513011900	19.0	93	188	8
4513012000	20.0	100	201	8
4513012200	22.0	107	215	8
4513012400	24.0	115	231	8

●: Excellent ○: Good

P		H		M		K		S			N				O	
11	12	15	21	22	31	32	41	42	43	61	62	63	64	81	82	
○	○	○	○	○	○	○				○	○	○	○	○	○	
13	14	16	23		33	34	51	52	53	71	72	73	74	83		
○	○	○	○		○	○				○	○	○	○			

# HAND REAMER L/H SPIRAL FLUTE



HSS DIN 206 H7 LH7°

Series No. 451301

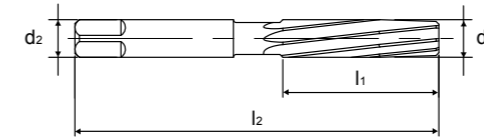

O.D. Tolerances : DIN 1420 for H7  
Shank Diameter = Nominal Reamer Diameter  
L/H Spiral Flutes / Right Hand Cut

Chamfer Angle - Tapered  
Type of centre - Up to Ø3.75 : external centres  
- Over Ø3.75 : internal centres

EUROPA CODE	NOMINAL SIZE d1 = d2	FLUTE LENGTH l1	OVERALL LENGTH l2	NO.OF FLUTES
4513012500	25.0	115	231	8
4513012600	26.0	115	231	8
4513012700	27.0	124	247	10
4513012800	28.0	124	247	10
4513012900	29.0	124	247	10
4513013000	30.0	124	247	10
4513013100	31.0	133	265	10
4513013200	32.0	133	265	10
4513013300	33.0	133	265	10
4513013400	34.0	142	284	10
4513013500	35.0	142	284	10
4513013600	36.0	142	284	10
4513013700	37.0	142	284	10
4513013800	38.0	152	305	10
4513013810	38.1	152	305	10
4513013900	39.0	152	305	10
4513014000	40.0	152	305	10
4513014100	41.0	152	305	12
4513014200	42.0	152	305	12
4513014300	43.0	163	326	12
4513014400	44.0	163	326	12
4513014500	45.0	163	326	12
4513014600	46.0	163	326	12
4513014700	47.0	163	326	12
4513014800	48.0	174	347	12
4513014900	49.0	174	347	12
4513015200	52.0	174	347	12
4513016000	60.0	184	367	12

●: Excellent ○: Good

P		H		M		K		S			N				O	
11	12	15	21	22	31	32	41	42	43	61	62	63	64	81	82	
○	○	○	○	○	○	○				○	○	○	○	○	○	
13	14	16	23		33	34	51	52	53	71	72	73	74	83		
○	○	○	○		○	○				○	○	○	○			

# REAMER CUTTING CONDITIONS



## 452303, 453303 (Carbide Chucking)

Material Group	vc (m/min)	fn (mm/rev)					
		ø2.0 -4.9	ø5.0 -8.9	ø9.0 -12.9	ø13.0 -19.9	ø20.0 -30.0	>ø30.0
<b>P</b>	11 <b>16</b> (14-18)	0.11 (0.10-0.12)	0.16 (0.12-0.20)	0.23 (0.20-0.25)	0.28 (0.25-0.30)	0.35 (0.30-0.40)	-
	13 <b>13</b> (12-14)	0.09 (0.08-0.10)	0.13 (0.10-0.16)	0.18 (0.16-0.20)	0.23 (0.20-0.25)	0.28 (0.25-0.30)	-
<b>H</b>	15 <b>11</b> (10-12)	0.09 (0.08-0.10)	0.13 (0.10-0.16)	0.18 (0.16-0.20)	0.25 (0.20-0.30)	0.28 (0.25-0.30)	-
	16						
<b>M</b>	21 <b>7</b> (6-8)	0.09 (0.08-0.10)	0.13 (0.10-0.16)	0.18 (0.16-0.20)	0.25 (0.20-0.30)	0.28 (0.25-0.30)	-
	22						
	23						
<b>K</b>	31 <b>18</b> (15-20)	0.11 (0.10-0.12)	0.16 (0.12-0.20)	0.23 (0.20-0.25)	0.28 (0.25-0.30)	0.35 (0.30-0.40)	-
	32						
	33 <b>13</b> (11-15)	0.11 (0.10-0.12)	0.16 (0.12-0.20)	0.23 (0.20-0.25)	0.28 (0.25-0.30)	0.35 (0.30-0.40)	-
<b>S</b>	41 <b>14</b> (12-16)	0.11 (0.10-0.12)	0.16 (0.12-0.20)	0.23 (0.20-0.25)	0.28 (0.25-0.30)	0.35 (0.30-0.40)	-
	42						
	43						
	51 <b>10</b> (8-12)	0.09 (0.08-0.10)	0.13 (0.10-0.16)	0.18 (0.16-0.20)	0.23 (0.20-0.25)	0.28 (0.25-0.30)	-
	52						
<b>N</b>	61 <b>23</b> (20-25)	0.11 (0.10-0.12)	0.16 (0.12-0.20)	0.23 (0.20-0.25)	0.28 (0.25-0.30)	0.35 (0.30-0.40)	-
	62						
	63						
	64						
	71 <b>50</b> (40-60)	0.14 (0.12-0.16)	0.20 (0.16-0.25)	0.28 (0.25-0.30)	0.35 (0.30-0.40)	0.45 (0.40-0.50)	-
<b>O</b>	72						
	73 <b>25</b> (20-30)	0.14 (0.12-0.16)	0.20 (0.16-0.25)	0.28 (0.25-0.30)	0.35 (0.30-0.40)	0.45 (0.40-0.50)	-
	74						
81 <b>18</b> (15-20)	0.14 (0.12-0.16)	0.20 (0.16-0.25)	0.28 (0.25-0.30)	0.35 (0.30-0.40)	0.45 (0.40-0.50)	-	
82							

vc - cutting speed (m/min)  
n - RPM (rev/min)  
fn - feed rate (mm/rev)  
ø - reamer diameter (mm)

$$\text{To calculate RPM from cutting speed: } n = \frac{v_c \cdot 1000}{\pi \cdot \phi}$$

$$\text{To calculate cutting speed from RPM: } v_c = \frac{n \cdot \pi \cdot \phi}{1000}$$

All recommendations are based on ideal machining conditions. Adjustments may need to be made according to your set-up. The recommendations for speeds, feeds and other parameters presented in this chart are nominal recommendations and should be considered only as good starting points.

# REAMER CUTTING CONDITIONS



## 452302, 453302, 455302, 456302, 457301 (HSS-E Chucking, HSS & HSS-E Morse Taper)



Material Group	vc (m/min)	fn (mm/rev)					
		ø2.0 -4.9	ø5.0 -8.9	ø9.0 -12.9	ø13.0 -19.9	ø20.0 -30.0	>ø30.0
<b>P</b>	11 <b>14</b> (12-16)	0.10 (0.05-0.15)	0.15 (0.10-0.20)	0.20 (0.15-0.25)	0.25 (0.20-0.30)	0.32 (0.25-0.40)	0.42 (0.35-0.50)
	12						
<b>H</b>	13 <b>11</b> (10-12)	0.08 (0.05-0.10)	0.12 (0.08-0.16)	0.15 (0.10-0.20)	0.20 (0.15-0.25)	0.25 (0.20-0.30)	0.35 (0.30-0.40)
	14						
<b>M</b>	15 <b>5</b> (4-6)	0.06 (0.03-0.08)	0.08 (0.06-0.10)	0.12 (0.08-0.15)	0.15 (0.10-0.20)	0.20 (0.15-0.25)	0.25 (0.20-0.30)
	16						
<b>K</b>	21 <b>5</b> (4-6)	0.06 (0.03-0.08)	0.08 (0.06-0.10)	0.12 (0.08-0.15)	0.15 (0.10-0.20)	0.20 (0.15-0.25)	0.25 (0.20-0.30)
	22						
	23						
<b>N</b>	31 <b>13</b> (12-14)	0.10 (0.05-0.15)	0.15 (0.10-0.20)	0.20 (0.15-0.25)	0.25 (0.20-0.30)	0.32 (0.25-0.40)	0.42 (0.35-0.50)
	32						
	33 <b>11</b> (10-12)	0.08 (0.05-0.10)	0.12 (0.08-0.16)	0.15 (0.10-0.20)	0.20 (0.15-0.25)	0.25 (0.20-0.30)	0.35 (0.30-0.40)
<b>O</b>	61 <b>17</b> (16-18)	0.15 (0.10-0.20)	0.20 (0.15-0.25)	0.25 (0.20-0.30)	0.32 (0.25-0.40)	0.42 (0.35-0.50)	0.50 (0.40-0.60)
	62						
	63						
	64						
	71 <b>18</b> (16-20)	0.15 (0.10-0.20)	0.20 (0.15-0.25)	0.25 (0.20-0.30)	0.32 (0.25-0.40)	0.42 (0.35-0.50)	0.50 (0.40-0.60)
<b>O</b>	72						
	73						
	74						
81 <b>10</b> (8-12)	0.15 (0.10-0.20)	0.25 (0.20-0.30)	0.35 (0.30-0.40)	0.45 (0.40-0.50)	0.55 (0.50-0.60)	0.70 (0.60-0.80)	
82							

## 454302 (HSS-E Quick Spiral)



Material Group	vc (m/min)	fn (mm/rev)					
		ø2.0 -4.9	ø5.0 -8.9	ø9.0 -12.9	ø13.0 -19.9	ø20.0 -30.0	>ø30.0
<b>P</b>	11 <b>17</b> (16-18)	0.12 (0.08-0.16)	0.21 (0.16-0.25)	0.25 (0.20-0.30)	0.35 (0.30-0.40)	0.35 (0.30-0.40)	-
	12						
<b>N</b>	13 <b>15</b> (14-16)	0.12 (0.08-0.16)	0.21 (0.16-0.25)	0.25 (0.20-0.30)	0.35 (0.30-0.40)	0.35 (0.30-0.40)	-
	14						
<b>O</b>	61 <b>18</b> (16-20)	0.12 (0.08-0.16)	0.21 (0.16-0.25)	0.25 (0.20-0.30)	0.35 (0.30-0.40)	0.35 (0.30-0.40)	-
	62						
	63						
	64						
	71 <b>20</b> (18-22)	0.15 (0.10-0.20)	0.25 (0.20-0.30)	0.35 (0.30-0.40)	0.50 (0.40-0.60)	0.50 (0.40-0.60)	-
<b>O</b>	72						
	73						
	74						
81 <b>13</b> (12-14)	0.15 (0.10-0.20)	0.25 (0.20-0.30)	0.35 (0.30-0.40)	0.50 (0.40-0.60)	0.50 (0.40-0.60)	-	
82							